

Laboratory Safety

California State University, Long Beach
College of Engineering

Information

- By reviewing this safety Powerpoint and completing the online quiz, you verify that you have been instructed regarding safety rules, regulations, and practices associated with the use of laboratory materials, equipment, and/or other potentially hazardous items associated with this course.
- You agree that you will abide by these safety practices as instructed. You further agree that you will not operate any equipment and/or use any material(s) that may be subsequently introduced in this course without appropriate instruction, supervision, and understanding of the potential hazards involved. If you have **ANY** questions, please ask your instructor **PRIOR** to starting and lab and/or using the equipment.

Overview

- General Lab Rules
- Personal Hygiene
- Housekeeping
- Protective Clothing and Equipment
- Chemical Hazards
- Physical Hazards
- Ventilation
- Emergency Response

General Lab Rules I

- **For the chemicals you are working with, you should be familiar with the:**
 - Standard Operating Procedure (SOP) for using that chemical in your lab (aka the protocol)
 - Hazards associated with that chemical
 - Personal protective equipment (PPE) required for using that chemical
 - Storage requirements
 - Waste disposal procedures
 - Procedures to be followed in the event of an emergency

General Lab Rules II

- **Avoid working alone in the lab. If you must work after hours or on weekends:**
 - Make arrangements with others in the building to check in with you periodically.
 - Let someone know you are working alone, and make arrangements to call and check in periodically.
 - Avoid conducting hazardous experiments during this time.
 - Do the most hazardous aspects of your work during regular work hours when others are present.

Personal Hygiene I

- Always remove gloves before leaving the lab.
- Wash well before leaving the lab, even if it's only for a short break.
 - Use soap and water, not solvents (which may enhance absorption of the chemical by the skin).
 - Wash immediately whenever any chemical comes in contact with your skin. Flush for at least 15 minutes.
- Avoid inhalation of chemicals.
 - Do not sniff a chemical in order to identify it

Personal Hygiene II

- No food or drink is allowed in the lab or in chemical storage areas. This includes gum and candy.
- Applying cosmetic products in the lab is not permitted.
- Use of tobacco products is not permitted in the lab. Smoking is prohibited in all CSULB facilities.
- Never pipet any chemical by mouth.
- Tie long hair back.
- Remove jewelry.

Housekeeping I

- Keep access to emergency shower and eye wash stations clear at all times.
- Test emergency shower and eye wash weekly to make sure they deliver continuous, clean, lukewarm water. Document the weekly tests on tags.
- Keep work areas free of clutter.
- Keep all aisles, stairs, corridors, and stairwells free of equipment, boxes, chemicals, and debris.
- Never bring food or drinks into a lab.
- To reduce the chance of breakage (and a contaminated oven), never use a mercury thermometer in an oven or incubator.

Housekeeping II

- **Frequently monitor chemical storage areas:**
 - Inspect for broken, deteriorating, or leaking containers.
 - Ensure that all containers are clearly labeled with the full name and hazard of the chemical (e.g. “Hydrochloric acid, corrosive” or “Ethanol, flammable”).
 - Store hazardous chemicals and wastes in secondary containment. Secondary containment capacity must be 110% of the largest container or 10% of the aggregate volume of all containers, whichever is larger.

Housekeeping III

- Put chemicals back into their proper storage location at the end of the day.
- At the end of a work day, any chemical in an unlabeled container should be considered waste and disposed of appropriately.
- Broken glassware, microscope slides, Pasteur pipets, etc. must be collected in a puncture-resistant container and labeled with the words “Broken glass disposal.”

Housekeeping IV

- **Waste collection containers must be:**
 - Clearly labeled with the full name(s) [no abbreviations] of the chemical(s) and the hazard(s) they present
 - Compatible with the chemical
 - Intact, with a lid or cap that can be sealed.

- **When waste collection containers are full, contact:**
 - Chibuzo Obiefuna
 - COE Safety Officer
 - ECS-621
 - Chibuzo.obiefuna@csulb.edu

Housekeeping V

Disposal of empty chemical containers:

- *Water-soluble nonregulated chemicals*
 - Examples: sodium chloride, magnesium sulfate
 - Triple rinse with water, deface label, mark as “Empty,” discard in regular trash.
- *Water-soluble regulated chemicals:*
 - Examples: ethanol, formalin, methanol
 - Triple rinse with water (collect rinses in waste container).
 - Deface label, mark with “Empty,” discard in regular trash.

Housekeeping VI

- **Disposal of empty chemical containers:**

- Non-water soluble chemicals*

- Examples: phenol, oils, some alcohols
 - Triple rinse with a solvent that will remove the chemical, collecting all rinses in a hazardous waste collection container
 - Deface label, label as “Empty”, and dispose in normal trash

Personal Protective Equipment (PPE) I

- **General clothing requirements:**
 - Wear long pants and long-sleeved shirts when working with chemicals.
 - Avoid wearing excessively loose or baggy clothing.
- **Lab coats and aprons:**
 - Wear lab coats while working with chemicals.
 - Chemical-resistant (Tychem[®], Saranex, or similar fabric) coats are recommended for particularly hazardous chemicals. Refer to the Material Safety Data Sheets (MSDS) regarding more specific PPE.
 - Full-length rubber, neoprene, or plastic aprons are recommended when there is a risk of a splash or spill.

Personal Protective Equipment (PPE) II

- **Use appropriate gloves for material you're working with:**
 - Heat-resistant for handling hot items, cryoprotective for handling liquid nitrogen
 - Chemical resistant: material depends on type of chemical being used (Review the Safety Data Sheets (SDS) to determine if special gloves are needed).
- **Understand the limitations of gloves:**
 - Chemicals do break through the material over time. Do not reuse disposable gloves
- **Change gloves often.**

Personal Protective Equipment (PPE) III

- **Eye protection:**
 - Use safety glasses when there's a chance of a small splash to the eyes, such as when opening a bottle or tube.
 - Use safety goggles when using a highly caustic/corrosive chemical, or when using large volumes (1 L or more) of a chemical.
 - Use full face shields when working with very large amounts of hazardous/corrosive chemicals, or when you need to protect your entire face.

Personal Protective Equipment (PPE) IV

■ **Footwear:**

- NEVER wear sandals or open-toed shoes in the lab.
- Non-permeable shoes (no open mesh) are preferable.
- Wear low-heeled shoes with non-slip soles.
- If handling large volumes of hazardous chemicals (corrosives, solvents), wear rubber boots or Tyvek® foot coverings.

■ **Inspection:**

- Always inspect your PPE prior to use.
- Look for cracks, holes, weak spots, or obvious signs of degradation.

Chemical Hazards I

- **Chemical hazards fall into 4 main categories:**
 - Flammables
 - Corrosives
 - Reactive chemicals
 - Health hazards

Chemical Hazards II

■ Flammables classification:

- Class IA: Flash point <73 °F, boiling point (bp) 100 °F
Ethyl ether, pentane
- Class IB: Flash point <73 °F, bp >100 °F
Acetone, ethanol, methanol, isopropanol, gasoline
- Class IC (combustible): Flash point 73-100 °F
Butanol, xylene, turpentine
- Class II: Flash point 100-140 °F
Formaldehyde, kerosene

■ Maximum container sizes:

- Glass: 500 mL (IA), 1 L (IB) 1 gal. (1C, II)
- Plastic: 1 gal. (IA), 5 gal. (IB, IC, II)
- Safety can: 2 gal. (IA), 5 gal. (IB, IC, II)

Chemical Hazards III

- **Flammables storage and labeling:**
 - Flammables are color-coded **red**
 - DOT hazard class 3
 - Must be stored in a flammable cabinet, away from sources of heat and/or ignition (sparks) at all times



Flammables
Self Reactives
Pyrophorics
Self-Heating
Emits Flammable Gas
Organic Peroxides

Chemical Hazards IV

■ Flammables handling:

- Never use an open flame to heat flammable materials. Instead, use hot water bath, oil bath, heating mantle, etc.
- Transfer from 5-gallon containers to smaller containers in a fume hood or approved flammable liquid storage room.
- Handle only in areas free of ignition sources.
- Do not transfer Class I flammable liquids in an exit way.

Chemical Hazards V

- **Corrosives definition:**
 - Cause rapid erosion and destruction of building materials or metals
 - Burn, irritate, or cause destruction to organic tissues such as skin, eyes, lungs, and stomach
 - DOT hazard class 8
- **Know the location and proper use of spill kits in your lab.**
 - Never use combustible organic materials (such as paper, sawdust, or rags) to clean up spills.

Chemical Hazards VI

- **Corrosives classification, labeling, and storage:**

Acids

- Are color-coded **WHITE**
- Store liquids and solids in corrosive cabinet, separate from bases
- Keep below eye level

Bases

- Are color-coded **WHITE**
- Solids may be stored on shelf in lab, away from other chemicals and below eye level.
- Liquids may be stored in a cabinet, away from acids. Use secondary containment for liquids.



Chemical Hazards VII

- **Corrosives handling:**
 - Never pour water into acid. Always add the acid to the water. Add acid slowly, with stirring.
 - Open bottles of acid slowly and carefully. Wear PPE (gloves, goggles/shield, apron) to protect against splashes.
 - Conduct all work with concentrated acids and bases in a chemical fume hood.
 - Check location of eyewash and shower before beginning work.
- **Some acids require special handling:**
 - Consult with instructor for assistance prior to handling.

Chemical Hazards VIII

- **Corrosives wastes:**
 - Never mix acid wastes with solvents or metal-containing solutions.
 - Never dispose of acids or bases down the drain unless they have been neutralized.
 - Non-contaminated (e.g. free of other hazardous chemicals) acid wastes may be neutralized and then disposed of down the drain (pH must be between 5 and 10).
 - Some exceptions apply. Corrosives that have other hazardous properties should not be disposed of down the drain even after neutralization (ex. hydrofluoric acid, fuming nitric acid, phenol, perchloric acid, etc.).

Chemical Hazards IX

■ Corrosives wastes contact:

- Information regarding disposal procedures.
- Assistance with neutralizing large volumes (>1 gallon or 1 pound) of corrosive solutions or materials.
- Questions or concerns.

Chibuzo Obiefuna

COE Safety Officer

ECS-621

Chibuzo.obiefuna@csulb.edu

Note: Empty bottles should be triple-rinsed with water (collect rinse solutions in waste acid container) before disposal or reuse of the bottle.

Chemical Hazards X

- **Reactives and oxidizers definition:**
 - Chemicals which will “vigorously polymerize, decompose, condense, or become self-reactive under conditions of shock, pressure or temperature” (29 CFR 1910.1450(b))
 - Chemicals which react violently when exposed to air or water
- Oxidizers cause other substances to burn more easily
- DOT hazard class 5



Explosive



Oxidizer

Chemical Hazards XI

- **Examples of reactives:**
 - Nitrate salts (Na, K, Ag)
 - Perchloric, nitric, and picric acids
 - Ammonium persulfate
- **Storage and handling:**
 - Reactive chemicals are color-coded **Yellow**
 - Store away from incompatible materials (consult Material Safety Data Sheets (MSDS) for more information).
 - Protect from exposure to conditions that would make the chemical unstable (air, water, heat, shock, etc.).

Health Hazards I

- **Definition of health hazard:**

- Chemical that causes adverse health effects, whether short-term (acute) or long-term (chronic)
- Includes toxins, carcinogens, teratogens, mutagens, poisons, biohazards (infectious agents)
- DOT hazard class 6
- Examples: Mercury and other metal compounds, ethidium bromide, formaldehyde

- **Storage:**

- Health hazards are color-coded **BLUE**
- Health hazards should be segregated from other chemicals

Health Hazards II: Pictograms



Acute Toxicity (fatal or toxic)



Carcinogen
Mutagenicity
Reproductive Toxicity
Target Organ Toxicity
Aspiration Toxicity



Irritant (skin and eye)
Skin Sensitizer
Acute Toxicity (harmful)
Narcotic Effects
Respiratory Tract Irritant
Hazardous to Ozone Layer



Biohazard (infectious agents)

Health Hazards III

- **Handling chemicals:**
- Always wear appropriate gloves and other suitable PPE when handling health hazards.
- Know hazards presented by the chemical you are working with.
- Possible routes of exposure (vary with chemical and procedure) include: skin absorption, inhalation, ingestion, injection.
- Symptoms of exposure may be acute and/or delayed (including chronic effects). Read the Material Safety Data Sheets (MSDS) !
- Be aware of possible adverse reactions with other chemicals or conditions (e.g. heat).

Physical Hazards

- **Include, but are not limited to:**
 - Machine guarding
 - Compressed gases
 - Electrical equipment
 - Lasers
 - Thermal hazards
 - Radiation

Physical Hazards II

- **Machine guarding:**
 - Required to prevent accidents.
 - Protects people, not machines.
 - Hazardous parts include point of operation components, control mechanisms, parts that transmit power, and parts that retain stored energy
 - Prevents injury from pinch points or physical contact.

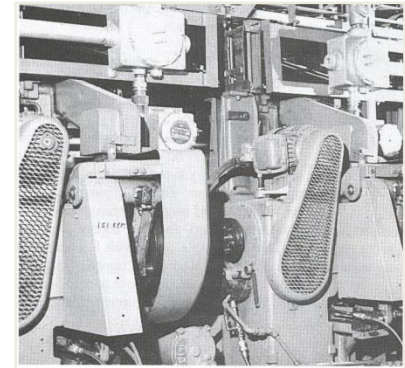

Physical Hazards III

- Moving parts make guards necessary

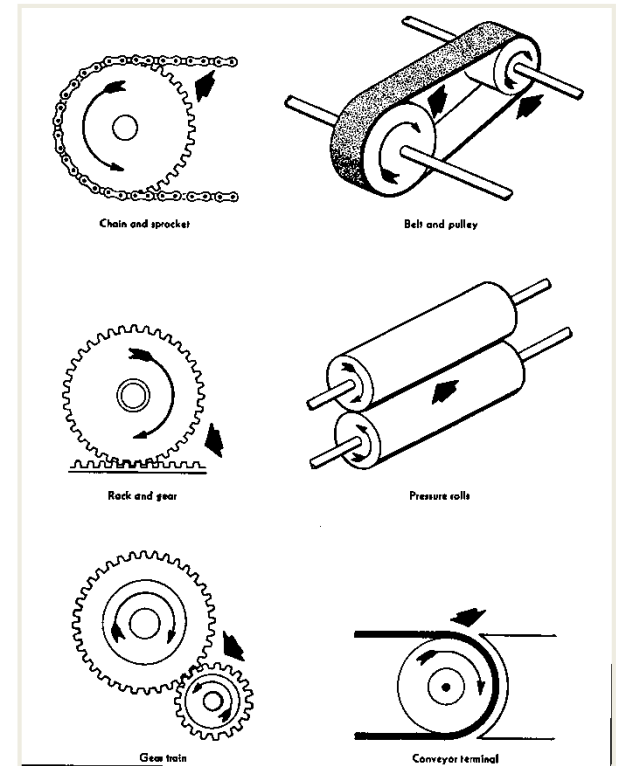
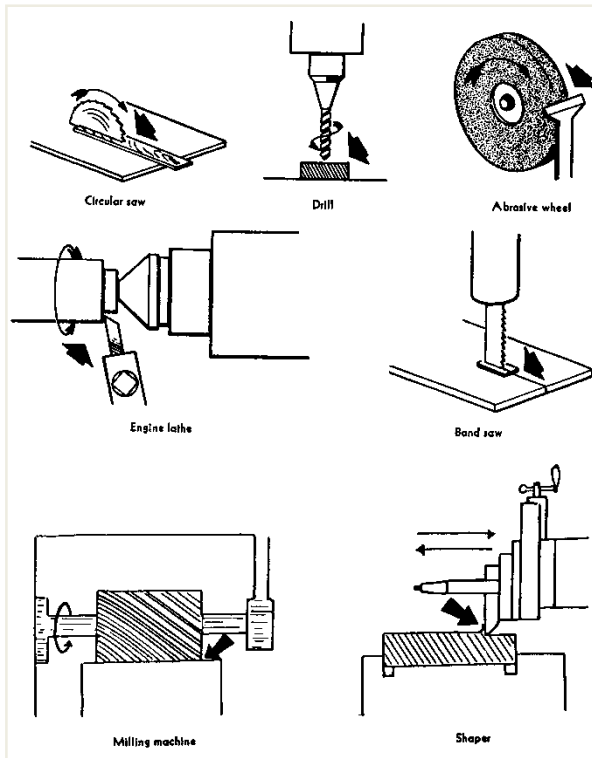

Physical Hazards IV

- Never, under any circumstances, remove any guarding on a machine while it is in operation.
- If equipment malfunctions, notify your instructor or laboratory technician. Do NOT attempt to address the malfunction yourself.
- Keep all hands away from pinch points on equipment while it is in service.
- Loose clothing, long hair, or any loose object is required to be secured away from moving parts PRIOR to any operation of equipment.

Physical Hazards V

- **Compressed gas cylinders:**
 - Must be restrained in an upright position in the lab.
 - Caps must be in place when cylinder is not in use.
 - Make sure regulator and supply lines are in good condition. Never use rigid plastic tubing, which can shatter if pressure limits are exceeded.
 - When turning on the gas:
 - Ensure flow valve is open (so there'll be no pressure in supply line). Adjust flow valve only after you've opened regulator.
 - Turn your head away from the tank.



Physical Hazards VI

- **Electrical equipment:**
 - Always inspect electrical cords prior to use.
 - Do not use if they are cracked or have exposed wiring.
 - Never use electrical appliances near water.
 - Make sure hands are dry when unplugging a cord.
 - Do not overload outlets.
 - Avoid excessive use or “daisy chaining” (several cords strung together) of extension cords.
 - Never override the safety features on electrical equipment.

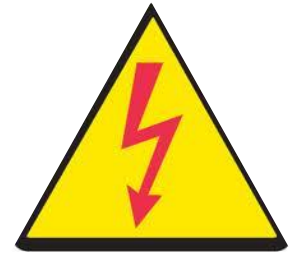

Physical Hazards VII

- **Lasers:**
- If you work with lasers in your lab, your Instructor/Professor must provide you with specific operating procedures and safety information prior to any handling or operating of equipment.



Physical Hazards VIII



- **Hot items:**
 - Use heat-resistant gloves when handling hot items.
 - Use caution when heating liquids on hot plates.
 - Use a stir bar or Boil-Eezers to ensure even heating of the liquids (to prevent superheating and boil-overs)
 - Never leave hot plates unattended.
- **Bunsen burners:**
 - Inspect tubing prior to using the burner. It should not have cracks, and should fit tightly to the burner and to the gas spigot.
 - Be alert to gas leaks along tubing. These can ignite.
 - Stand back from the burner when lighting the gas.

Physical Hazards IX

▪ Autoclaves:

- Wear heat-resistant gloves when loading an autoclave. The inner surfaces of the machine are hot.
- Wear face shield, rubber apron, and heat-resistant gloves when unloading an autoclave. Liquids can be superheated, and bottles can explode if jostled.
- Beware of hot water in the bottom of autoclave trays.
- Use deep tubs rather than shallow trays.
- Do not stand in front of the autoclave door while opening it—stand behind the door to avoid getting blasted with steam.

Physical Hazards X

- **Cold items:**
 - Ultra-cold freezers
 - Wear insulated gloves when accessing ultra-cold (-60 to -80 °C) freezers.
 - Bare skin can stick to cold surfaces, especially if fingers are damp.



Physical Hazards XI

▪ Liquid Nitrogen (LN2):

- Wear insulated or cryoprotective gloves when accessing LN2. **Note:** cotton gloves are not sufficient. Splashes of LN2 can easily penetrate the gloves, causing frostbite and serious injury.
- Wear face shield or splash goggles to protect face and/or eyes from splashes
- Use caution when adding items to LN2. Rapid addition of items can result in splashes to the face and hands.
- Tubes stored in LN2 should be thawed behind a shield.
- Sometimes LN2 leaks into the tube during storage. The nitrogen will rapidly expand upon warming, causing the tube to shatter.



Ventilation I

- **Chemical fume hoods:**
 - Keep sash at or below “maximum sash height” posted on fume hood.
 - Fume hoods are tested annually at CSULB for proper air flow.
 - If your fume hood does not have a current sticker, or if your fume hood does not seem to be working properly, contact the laboratory technician or your instructor for further information.



Ventilation II

- **Fume hoods guidelines:**
- Conduct all work at least 6” inside fume hood. This reduces the chance that vapors will backwash out of the hood due to air movement.
- Do NOT store chemicals in a fume hood.
- Do NOT block the vents at the back of the fume hood.
- If a large object must be placed inside the hood (e.g. a water or acid bath), elevate it slightly so that air can flow under the object.

Ventilation III

- **Canopy and snorkel:**
- These types of ventilation use physical properties of the chemical or process to capture exhaust (e.g. heat, lighter-than-air vapors).
- **Note:** Snorkel face must be within $\frac{1}{2}$ the duct diameter to the chemical or process being exhausted to work properly.

Canopy



Snorkel



Emergency Response I

- **Fire:**
 - If your clothing catches on fire, drop and roll to put out the flames. Immediately notify your supervisor of the incident.
 - Fire extinguishers are located near the entrance/exit doors in most of the buildings/rooms.
- **Chemical spill on clothing:**
 - Get to the safety shower immediately and remain there for at least 15 minutes.
 - Remove contaminated clothing while in the shower.
 - Notify your supervisor of the incident.

Emergency Response II

- Be aware of the fastest/safest exit.
- If alarm sounds, or authorities order an evacuation, leave promptly and
 - Take personal items
 - Turn off equipment being used (if possible).
- MUST KEEP 200 FEET away from the building upon evacuation.
- Follow your instructor to the common meeting area.

Emergency Response III

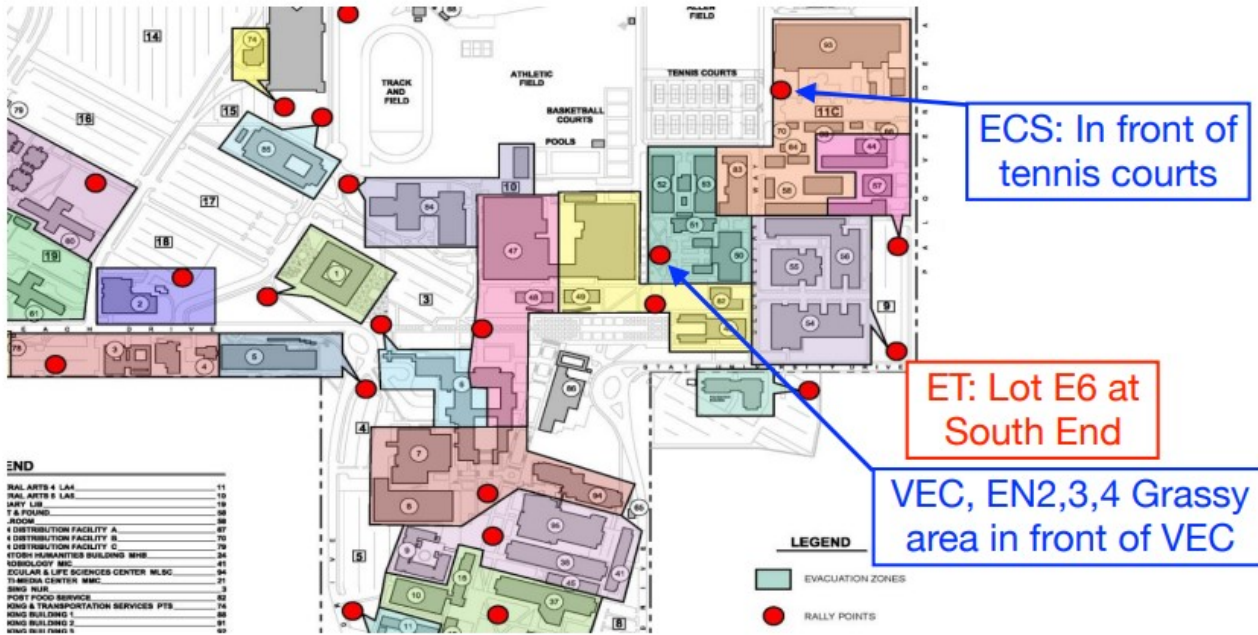

Emergency Response IV

- Emergency Phones located outside buildings and in elevators.
- Use them to speak directly to [CSULB POLICE](#).
- Text-to-911 is also available on campus and throughout Los Angeles and Orange Counties
- Dial 911 from any phone or Text 911 from Cellphone

Emergency Response V



Building Hallways Wall
Emergency Phone Boxes



University
Emergency
Phone Box



Elevator Emergency
Phone Box

Emergency Response VI

- **Chemical splashes to the eye:**
 - Immediately go to the eye wash station and flush eyes with water for at least 15 minutes.
 - Hold lids open to let water to reach all surfaces of eye and eyelids.
 - Seek medical attention.
 - Notify your supervisor of the incident immediately.
- **Burns:**
 - Immerse burned area under cold, running water as soon as possible.
 - Seek medical attention.
 - Notify your supervisor of the incident immediately.

Emergency Response VII

- **Chemical spills involving hazardous materials:**
 - If you don't feel comfortable cleaning up the spill, call EHS in Facilities at 562.985.2283 for help (never put yourself at risk).
 - Call **911** in the event of an emergency or if anyone is in danger. After hours, call dispatch at 562.985.4101.
 - Move away from the site of the hazard to a safe location.
 - Follow the instructions of emergency personnel.
 - Alert others to stay clear of the area.
 - Notify emergency personnel if you have been exposed or have information regarding the release.

Emergency Response VIII

- **Broken mercury thermometer:**
 - Isolate the area and do not let people walk through the contaminated zone. Mercury can be readily vaporized throughout a lab by people walking on the spill and splitting the mercury into smaller particles.
 - **DO NOT** attempt to clean up the spill yourself, no matter how small. **Call EHS, Facilities Management at 985-2283.** They will bring a vacuum that is specifically designed for mercury spills.
 - Report all spills into sinks to EHS and Facilities Management immediately so residual mercury can be removed from sink trap.

Resources

- **EHS Facilities**
 - George Alfaro (562.985.2378)
 - Michael Kitahara (562.985.1761)
 - Glen Seymour (562.985.8746) COE Facilities/
Equipment
- **College of Engineering Safety**
 - Chibuzo Obiefuna (562.985.4544)
- **University Police**
 - Emergency Response (Call or Text 911)
 - General Assistance (562.985.4101)