



# FUTURE OF THE OFFICE

## BEST PRACTICES & SPACE STANDARDS



# CONTENTS

## 4 Chapter One

---

### FUTURE OF THE OFFICE

- 5 Evolution of the Office at CSULB
- 9 How to Use This Guide

## 10 Chapter Two

---

### FUTURE OF YOUR OFFICE

- 11 Finding the Right Strategy for Your Team
- 12 How to Manage Change
- 13 Steps to Configure Your Office Space
- 39 Helpful Resources

## 40 Chapter Three

---

### TIPS FOR OFFICE BEAUTIFICATION & CULTURE

- 41 Standard Office Setup
- 42 Designing Your Physical Space

# Chapter One



# THE FUTURE OF THE OFFICE

## The Evolution of the Office at CSULB

In 2018, the Beach community came together to imagine the world of 2030, and the myriad technological, economic, sociopolitical, and environmental changes that will impact higher education in the intervening decade.

The Imagine Beach 2030 event invited thousands of stakeholders – students, faculty, staff, and community members – to participate in a unique forum designed to elevate our collective voice on an unprecedented scale. This grassroots movement culminated with the creation of the Beach 2030 strategic plan that is currently underway.

Separately, but in line with our Beach 2030 vision to align our space usage with our future goals, Beach Building Services conducted a campus-wide evaluation of our overall space efficiency in a 2019 study. It provided a baseline on how we could more effectively leverage our current space. Then, in 2020, the COVID crisis tested our ability as a campus to adapt to a rapid shift in the way we work. We now have an opportunity to capitalize on lessons learned.

As we embrace hybrid work, our perspective of the office must evolve. Utilizing a holistic approach to assess multiple factors that influence work, the workforce, and the workplace – and how those factors align with our strategic pillars – is critical to our success.

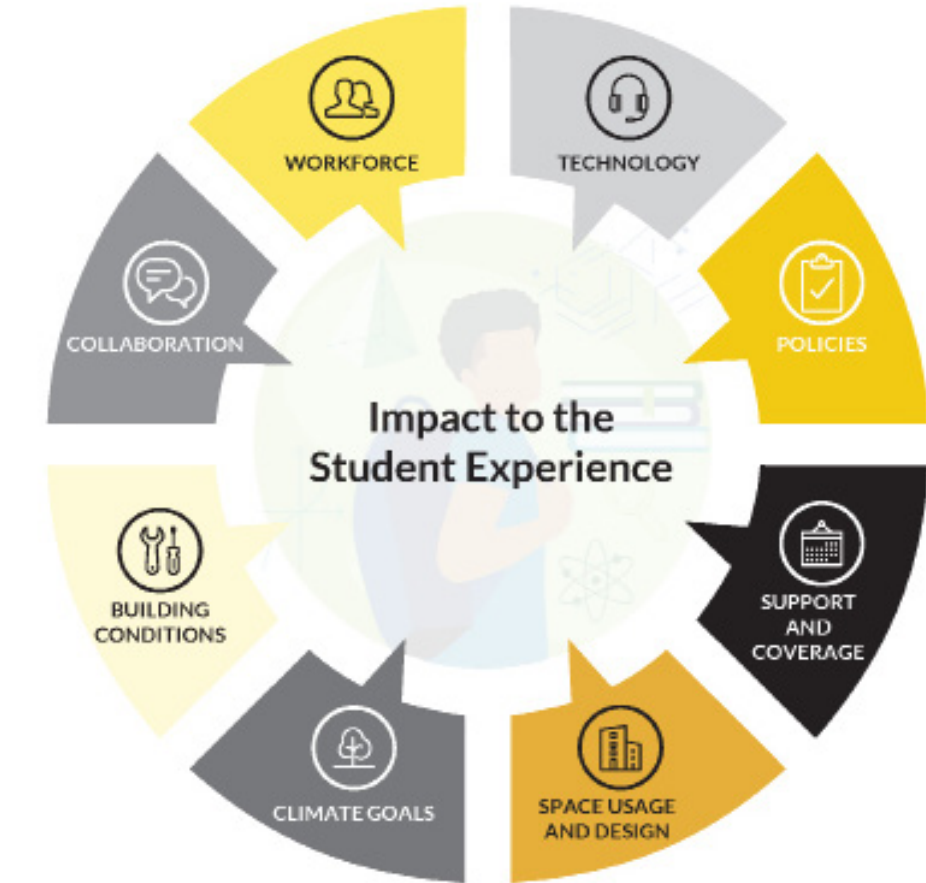

## The Future of Work Project

In 2022, our campus launched the Future of Work initiative as a key component of the Beach 2030 strategic plan. The goal: To align work practices with the needs of students, customers, and the workforce, while also considering social, technological, environmental, economic, and political influences on the workplace.

The team behind Beach 2030's Reimagine Staff Action Zone, in collaboration with Deloitte Inc., spearheaded the effort to analyze our current state and develop a comprehensive roadmap for the

Future of Work at CSULB. This project examined key workplace factors, including workforce dynamics, technology, services, collaboration methods, and physical space.

Four "Guiding Principles" were established based on campus feedback, which are also in alignment with industry trends and modern higher education institutional practices. Additionally, 12 recommended initiatives were developed, grounded in the guiding principles and aligned with the campus strategic priorities and Beach 2030 goals.

## Guiding Principles



## The Office of the Future

While hybrid schedules have improved the way we work in many ways, they have also led to increased feelings of isolation, decreased collaboration among employees, and an overall perception of "emptiness" by students, co-workers, and other customers. Traditional office use allocation, which emphasized a 1:1 ratio for individual office space, has given way to new hybrid work allocations, where office space may be shared. These alternative workspaces will focus on innovation, collaboration, learning, socialization, and employee experience.

Our overall decrease in office occupancy levels, coupled with hybrid work, gives us an opportunity to reinvent ourselves. The office of the future is a vibrant space — no matter if you're in a physical place on campus or tapped into our university network remotely. With technologies that make the working experience seamless across alternative schedules and hybrid arrangements, opportunities for cross-campus collaborations are easier than before. And because our infrastructure is designed to be efficient across all platforms, the services we deliver are adaptable to the breadth of needs across our campus and customers.

To reach our future vision, the Beach 2030 Reimagine Staff Action Zone team and Beach Building Services came together to assess space utilization and hybrid work recommendations. Existing guidelines around CSULB work arrangements were evaluated and aligned with modern work principles, leading to the development of a new process that incorporates today's work considerations as we reassess our physical space — starting with the "Five Cs" of in-person work. Even though jobs may vary widely, these five elements represent factors ever-present in any role.

Historic Office Use Allocation



Hybrid Work Office Use Allocation

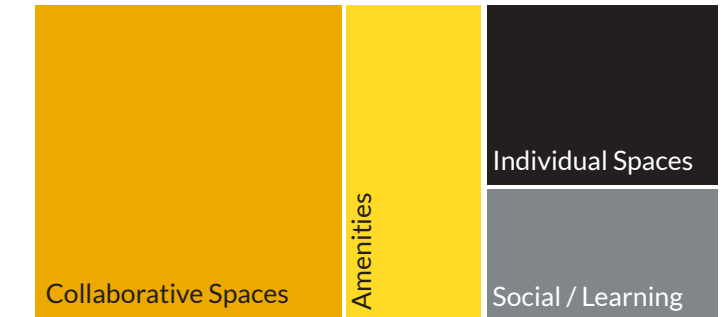

## Our Process & Vision

New office space standards developed by our Beach Building Services team establish configurations of your physical space. Before deciding on office sizes and workstations for your team, thoughtful consideration of your organization's unique work responsibilities should be taken into account.

The following pages will take you through our step-by-step process to help you determine the best use of your physical space, considering your team's scheduling arrangements and the work they perform at CSULB. It also includes tips for making your office a welcoming and energizing environment.

This begins with the "Five Cs" of modern work: key themes that should be present in every successful team. It is important to consider how connection, creation, collaboration, critical tasks, and culture impact your organization to foster personal connections, inspire creativity, facilitate teamwork, ensure efficiency in essential tasks, and promote a positive work environment.

## The Five Cs

### CONNECTION



While virtual communication can be meaningful and effective, in-person chats may be necessary (or fun!) under some circumstances. This is the power of personal connection!

### CREATION



One of the key benefits of a blended work model is the opportunity for planned or spontaneous interactions between coworkers that spark big ideas.

### COLLABORATION

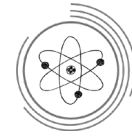

In some cases, gathering the team in person for strategic or collaborative events may be the best approach. This is the power of teamwork: Bringing people together to solve complex business challenges.

### CRITICAL TASKS



Certain troubleshooting and maintenance tasks must be performed in person, especially when repairing or replacing physical equipment.

### CULTURE



Reinforce the purpose and values by creating highly positive and engaging workplace experiences. In-person celebrations are a great way to foster social bonding and networking.

## How to Use This Guide

The guide begins with an assessment of how people work in your organization, then helps you identify what type of space strategy will maximize your office potential. These factors will then help determine the types of workspaces needed for your team and office. This guide also contains updated space guidelines and beautification strategies to enhance the look and feel of your space, which can foster a stronger sense of belonging in your organization.

At each step, you will be provided with the tools needed for a successful assessment, along with a list of campus resources that can help you achieve your goals.



## Chapter Two



## Finding the Right Strategy for Your Team

Flexible work arrangements — remote days, staggered scheduling, and shared office space — are key aspects of a holistic approach that can offer numerous benefits, including our ability to provide student- and customer-centric services.

The next several pages will guide you through a step-by-step process to help determine the best way to configure your space, given your team's unique job duties, culture, and work schedules.



## How to Manage Change

When configuring your space, your ability to manage the change in your office proactively will help build your team's culture and ensure a smooth transition.

### Involve Employees Early

- Discuss the shift with employees early on so they feel empowered
- Be open to suggestions

### Create Structure

- Create standards early on
- Invest in reliable reservation software (if applicable)
- Appoint an individual to oversee new practices and address employee satisfaction and needs

### Provide Diversity & Comfort

- Supply diverse work stations and seating arrangements to accommodate different preferences
- Provide ergonomic and varied furniture to meet diverse needs

## Steps to Configure Your Office Space

### Step 1. Determine How Your Team works



The traditional one-to-one ratio for office space is no longer suitable for a modern hybrid work environment. Instead, we now must now consider several factors: how to best serve our students and customers, which employees are suitable for hybrid work, the extent to which they can work remotely, and how to design and configure work and collaboration spaces to support them in the office.

### Step 2. Consider Shared Space Strategies



The hybrid work environment offers CSULB the opportunity to explore various shared space strategies, increase space efficiency, and adjust working norms to better meet student service needs. Choose from a trio of space model best practices that can help achieve these outcomes.

### Step 3. How to Optimize Your Physical Space



Once a shared space model has been identified, there are several ways to assign space to individual employees. Using a mix of office space configurations can be beneficial to your overall productivity goals and culture. Beach Building Services can help implement physical space changes.

## Step 1

### How Your Team Works



## Consider Who You Serve & How Your Team Works

Since a one-to-one ratio for office space is no longer the standard in a modern hybrid work environment, we must adopt a holistic approach to how we work. This approach should include our ability to provide student- and customer-centric services.

This process begins with **determining whether your employees should engage in hybrid or “flexible” work schedules.**

Although flexible work schedules are analyzed at the individual employee level, it is important to consider the organization’s mission, its culture, and how services can be delivered most effectively to meet the needs of students and customers.

Staff Human Resources has developed the “Determining Flexible Work” tool to help managers consistently work schedules that best meet operational needs in their area. Decisions can be made by analyzing a series of considerations, such as:

- What is the required need for how and where the work can / should be performed?
- What is the nature of the work or job duties, and how is it done?
- Does remote work align with the unit’s culture of belonging and the preferred modality for customer service?
- With whom, how, and where does customer interaction occur?
- Is the tech structure in place to support work in alternative places?

## Step 1

### What Scheduling Options Fit Your Operations

**How your team works** — your takeaways from the questions on the previous page — should inform the in-person or remote work schedule for each employee. The type of space that may be allocated to an individual **will now be based on their schedule in the new process.**

Suggested options for employee flexible schedules are below.

<i>In-Person</i>	<i>High</i>	<i>Medium</i>	<i>Low</i>
<ul style="list-style-type: none"><li>• 100% of time on campus</li><li>• Assigned workspace; hoteling</li><li>• Campus operations require in-person job</li></ul>	<ul style="list-style-type: none"><li>• 80% (4 days) of time on campus</li><li>• Assigned workspace; hoteling; or overflow</li><li>• Job requires high in-person interaction</li></ul>	<ul style="list-style-type: none"><li>• 60% - 40% (3 -2 days) of time on campus</li><li>• Shared workspace; hoteling; or overflow</li><li>• Job requires medium in-person interaction</li></ul>	<ul style="list-style-type: none"><li>• Less than 20% of time on campus</li><li>• No assigned workspace; hoteling; or overflow</li><li>• Job functions are not workplace dependent</li></ul>

- **Remote Work:** Applies to individuals working from home or alternative locations, on or off campus, according to function and operational needs for customers, based on assigned schedule.
- **Alternate Schedules:** Leverages staggered team schedules, whether on campus or working remotely, to meet unique service needs of customers.

*Tools: Complete this **flexible work tool exercise** for each member of your team. The [Office Operations and Services Modality Matrix](#) can also help you visualize your in-person and remote operations.*





## Step 2

### Shared Space Strategies

Tools: Complete the [Shared Space Strategy Checklist](#) to help you meet your goals and adapt your operations. The [Office Operations and Services Modality Matrix](#) can also help you decide the appropriate space model for your team.



#### Consolidating Teams from Different Spaces

##### WHAT THIS LOOKS LIKE

This occurs when a department or division that currently occupies multiple spaces across campus identifies a central location and releases the additional space on campus. The goal is to centralize resources, streamline communication, and improve collaboration.



#### Co-locating Synergistic Teams

##### WHAT THIS LOOKS LIKE

This occurs when multiple departments or divisions with complementary functions or expertise, currently in separate spaces, consolidate into a preferred location on campus. These teams collaborate to achieve shared goals.



#### Creating One-Stop-Shops

##### WHAT THIS LOOKS LIKE

This model involves combining various services or functions into a single location. For example, a university might establish a student services center where students can access counseling, financial aid, and academic advising all in one place.

## Consider These Space Model Best Practices

We can now expand our perspective beyond traditional space ownership and strategically rethink how we organize services and functions. With a focus on students and customer needs, consider leveraging your team's flexible schedules to enhance culture and optimize occupancy using the shared space strategies outlined below.

These strategies, grouped into three categories, **enhance sustainability, space efficiency, and operational effectiveness while providing high-quality student services.** When choosing a shared space model, consider your organization's specific requirements and organizational culture.

Ultimately, the decision should align with your organization's goals, existing infrastructure, and the desired balance between efficiency and collaboration.

## Consolidating Teams From Different Spaces

This occurs when a department or division that currently occupies multiple spaces across campus identifies a central location and vacates the additional space on campus. The goal is to centralize resources, streamline communication, and improve collaboration.



## Step 2

### BENEFITS

- **Cost Efficiency:** Organizations can reduce overhead costs associated with maintaining multiple spaces.
- **Enhanced Communication:** Proximity fosters better communication and knowledge sharing among team members.
- **Resource Optimization:** Shared facilities (such as meeting rooms, equipment, and common areas) can be used more efficiently.
- **Promotes Culture:** Working alongside and interacting regularly with colleagues enhances department culture and strengthens teams.

### CONSIDERATIONS

- **Cultural Shift:** Team members may need to adapt to a new working environment and build relationships with colleagues from other areas.

## Co-locating Synergistic Teams

This occurs when multiple departments or divisions with complementary functions or expertise, currently in separate spaces, consolidate into a preferred location on campus. These teams collaborate to achieve shared goals. This option is ideal for groups with complementary roles that frequently work together or those that require similar spaces to complete their work on campus.



## Step 2

### BENEFITS

- **Cross-Pollination:** Synergistic teams can exchange ideas, leading to innovation and improved problem-solving.
- **Efficiency:** Co-located teams can work together seamlessly, reducing delays and enhancing productivity.
- **Resource Sharing:** Shared resources (such as specialized equipment or software) become more accessible.

### CONSIDERATIONS

- **Team Dynamics:** Ensuring that teams work well together and avoid conflicts is essential.

## Creating One-Stop Shops

This model involves combining various services or functions into a single location. For example, a university might create a student services center where students can access counseling, financial aid, and academic advising all in one place.

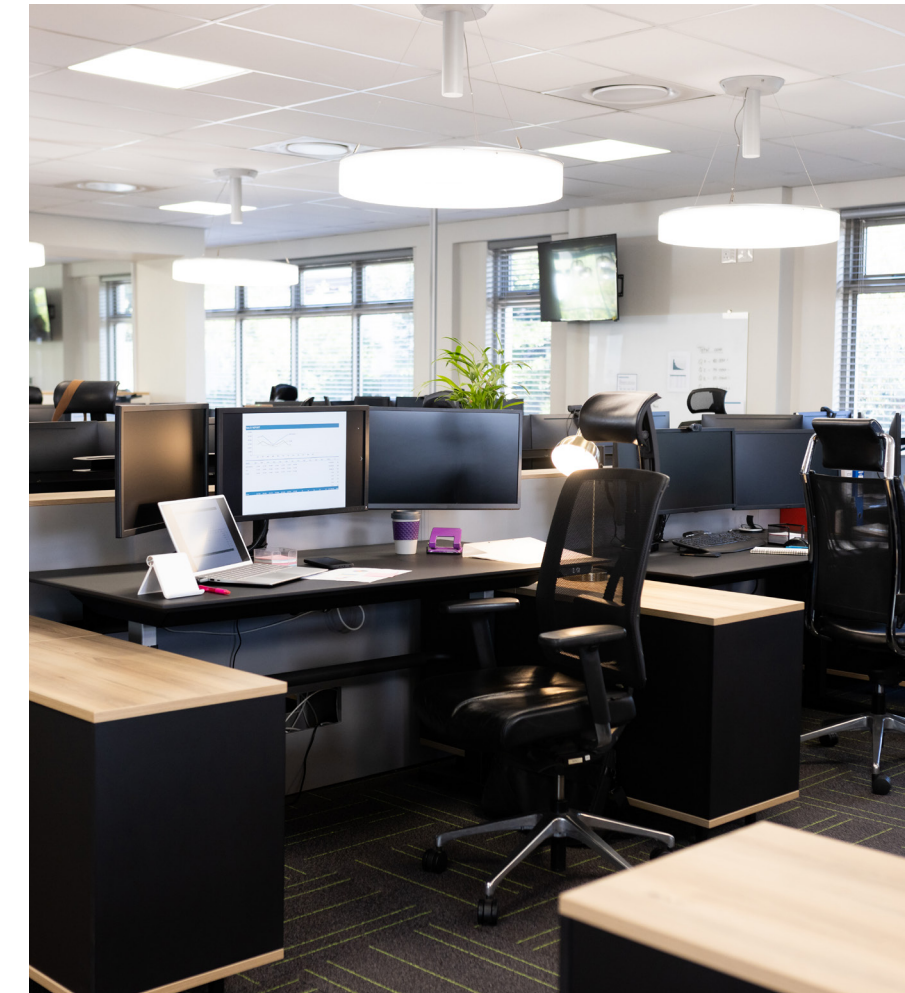

## Step 2

### BENEFITS

- **Convenience:** Users (students, employees, or customers) find it easier to access multiple services without traveling to different locations.
- **Streamlined Processes:** Centralized services reduce bureaucracy and simplify administrative tasks.
- **Improved User Experience:** One-stop shops enhance satisfaction by offering comprehensive assistance.

### CONSIDERATIONS

- **Service Integration:** Ensuring seamless coordination among different service providers is essential.
- **Physical Space:** Designing a functional layout that accommodates various services and minimizes wait times is critical.



### Step 3

## Optimize Your Space

# Decide the Mix of Space Configurations

Now that you have determined the shared space strategy, you must identify what type of workspace concepts you will need.

The workspace concepts should align directly with the flexible work schedules of your employees and fall into the following categories: Hoteling, Neighborhoods, Desk Sharing, and Traditional Space. Remember, there is no “one size fits all.” You may choose to utilize a variety of these concepts as you work with Beach Building Services to design and configure your space.



### Hoteling

Open touch down “plug and play” seating for any employee to use, supported by a reservation system.



### Neighborhoods

Hoteling space available to designated employees, organized in sections based on team(s) or function.



### Desk Sharing

Two or more people using a shared workstation that is assigned and not available for use otherwise



### Traditional Space

1:1 Assigned workspace for each employee. While this concept is still applied in many spaces, this concept should only be utilized for people who are on campus five days a week.

Once there is an understanding of the three considerations for work in a department, college or division, Beach Building Services can then design a physical space that can facilitate all work styles while also being responsive to the organization’s culture, operational needs, its employees, and the students and customers they serve.

Once you know which approach you want to take, use these artifacts to help with the implementation.

Tool: Use the [workspace concept guides](#) to help you determine which options may be best for your office configurations.



## HOTELING WORKSPACE GUIDE

In a hoteling concept, individual workspaces can be reserved in advance and used by employees who do not have a fixed office location. This open touch down “plug and play” seating is typically supported by a reservation system.

Use the guide on the next page to help you determine whether this model may be effective for your team by examining the available infrastructure, opportunities, challenges, and ways in which those challenges can be overcome: resilience.



### INFRASTRUCTURE NEEDED

- Standard Office & Technology Set-up
- High availability of private, semi-private meeting and conference rooms for service delivery, collaboration, and critical work.
- Employee Lockers/Storage
- Reservation System

### OPPORTUNITIES

- High collaboration, flexibility and Mobility
- High shared Personalization and Culture
- High long-term Cost Savings
- High consolidation Opportunities
- High ability to repurpose unused space

### CHALLENGES

- Low focused, critical work
- Low privacy for employees
- Low visibility for managers
- High short-term investment for implementation

### RESILIENCE

- Private, semi-private meeting and conference rooms for service delivery, collaboration and critical work will offset the reduction in privacy for focused work and meetings
- Implementing office norms and shared work-flow systems will improve performance management and supervisory oversight in a hybrid workforce
- Focus shifts from individual to team-based personalization and culture. There is more emphasis on creating an inviting physical environment that is supported by team-based culture building activities
- Individual personalization takes place in new creative ways throughout the office
- Significant Reductions in deferred maintenance and operational costs
- Increase in employee morale, satisfaction and retention rates. Increase in ability to recruit talented employees in a vibrant and effective hybrid working environment

## NEIGHBORHOODS WORKSPACE GUIDE

In a neighborhoods model, hoteling space is allocated to designated employees and organized in sections based on team(s) or function. Teams or work groups can book these “neighborhoods” to work together easier.

Use the guide on the next page to help you determine whether this model may be effective for your team by examining the available infrastructure, opportunities, challenges, and ways in which those challenges can be overcome: resilience.



### Step 3



### Step 3

#### INFRASTRUCTURE NEEDED

- Standard office & technology set-up
- Moderate availability of private, semi-private meeting and conference rooms available for service delivery, collaboration, & critical work
- Lockers/storage for employees
- Reservation system

#### OPPORTUNITIES

- Moderate collaboration, flexibility, mobility
- Moderate focused, critical work
- Moderate privacy for employees
- High shared personalization & culture
- High long-term cost savings
- Moderate consolidation opportunities
- Moderate ability to repurpose unused space

#### CHALLENGES

- Low individual personalization options
- Low focused, critical work
- Low privacy for employees
- Moderate visibility for managers
- Moderate short-term investment for implementation
- Moderate consolidation opportunities
- Moderate ability to repurpose unused space

#### RESILIENCE

- Private, semi-private meeting and conference rooms for service delivery, collaboration and critical work will offset the reduction in privacy for focused work and meetings
- Implementing office norms and shared work-flow systems will improve performance management and supervisory oversight in a hybrid workforce
- Focus shifts from individual to team-based personalization and culture. There is more emphasis on creating an inviting physical environment that is supported by team-based culture building activities
- Individual personalization takes place in new creative ways throughout the office
- Significant reductions in deferred maintenance and operational costs
- Cost-savings can be re-utilized for the office
- Increase in employee morale, satisfaction and retention rates. Increase in ability to recruit talented employees in a vibrant and effective hybrid working environment

## DESK SHARING WORKSPACE GUIDE

In a desk sharing model, two or more people share an assigned workstation that is not available for use otherwise.

Use the guide on the next page to help you determine whether this model may be effective for your team by examining the available infrastructure, opportunities, challenges, and ways in which those challenges can be overcome: resilience.



### Step 3



### Step 3

#### INFRASTRUCTURE NEEDED

- Standard office & technology set-up
- Low availability of private, semi-private meeting and conference rooms available for service delivery, collaboration, and critical work
- Lockers/storage for employees

#### OPPORTUNITIES

- High focused, critical work
- High privacy for employees
- Moderate short-term investment for Implementation
- Moderate long-term cost savings
- Moderate consolidation opportunities
- Moderate ability to repurpose unused space

#### CHALLENGES

- Moderate collaboration, flexibility, and mobility
- Shared personalization and culture

#### RESILIENCE

- Implementing office norms and shared work-flow systems will improve performance management and supervisory oversight in a hybrid workforce
- Focus shifts from individual to team-based personalization and culture. There is more emphasis on creating an inviting physical environment that is supported by team-based culture building activities
- Individual personalization takes place in new creative ways throughout the office
- Cost-Savings can be re-utilized for the office
- Increase in employee morale, satisfaction and retention rates. Increase in ability to recruit talented employees in a vibrant and effective hybrid working environment

## TRADITIONAL SPACE WORKSPACE GUIDE

### Step 3

In a desk space concept, one workspace is assigned to each employee.

Use the guide on the next page to help you determine whether this model may be effective for your team by examining the available infrastructure, opportunities, challenges, and ways in which those challenges can be overcome: resilience.



### Step 3

#### INFRASTRUCTURE NEEDED

- Standard office & technology set-up
- Low availability of private, semi-private meeting and conference rooms available for service delivery, collaboration, and critical work

#### OPPORTUNITIES

- High focused, critical work
- High privacy for employees
- High individual personalization
- High visibility for managers
- No short-term investment for implementation

#### CHALLENGES

- Low collaboration, flexibility, and mobility
- Shared personalization and culture; feelings and perceptions of “emptiness” in a hybrid work environment
- No long-term cost savings
- No consolidation opportunities
- No ability to repurpose unused space

#### RESILIENCE

- This concept should be limited to individuals working four or more days a week in person

# How Should You Configure Your Space?

Once you have assessed your team’s work patterns and determined the most suitable shared space strategy and workspace concepts are best for your team, Beach Building Services (BBS) can assist in designing and configuring your space.

The BBS team has developed updated standard office configurations to help meet the needs of your office today and in the future. The following pages provide illustrated examples of the various options and recommendations on when they should be utilized.



# Meeting Rooms

There are various sizes and styles of meeting rooms. Small huddle rooms are ideal for quick discussions or small groups, while larger conference rooms suit presentations or team meetings.

Consider the meeting’s purpose and tailor the room to match the intended use, including technology, comfort and flexibility for various formats.

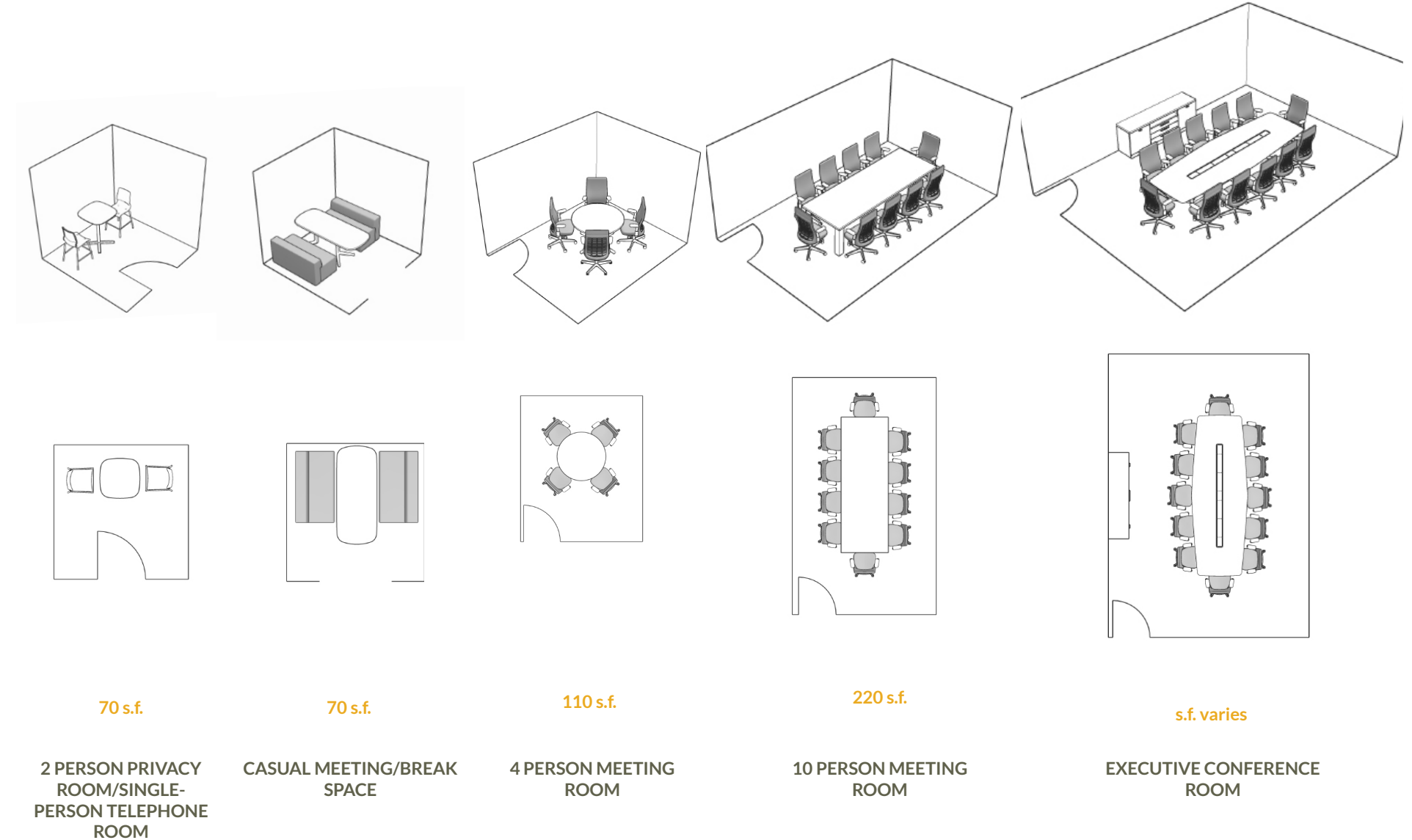



## Options for Meeting Room Add-ons

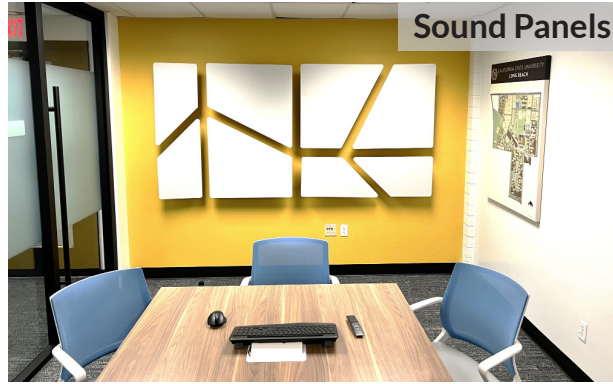

Sound Panels

In an era of hybrid work, acoustic quality is more important than ever. Participants at home need to have a sight and sound experience equivalent to those in the office. To support optimal acoustics, sound panels should be installed. These should be customized based on the size of the room and number of hard surfaces.



Standard AV Equipment

Standardize equipment used in each conference room for efficient technology use. Providing up-to-date equipment with seamless connectivity is essential for enhancing productivity. Tables should be equipped with built-in power outlets, USB ports, and audiovisual connectivity options to support various devices such as laptops, projectors, and video conferencing equipment.



Storage

Some level of basic storage should be provided in conference rooms. Basic supplies such as markers, coasters, and AV instructions can be stored there. Since conference rooms are meant to be shared to maximize space efficiency, there may be items in the room belonging to the local office that need to be stored while others from outside the office use the room.



Lighting

Appropriate lighting levels are needed in hybrid conference rooms. A mix of natural and artificial lighting can be used to support circadian rhythms and enhance well-being. For larger spaces, the use of 2-level lighting, with the ability to reduce lighting at the monitor or screen, can improve presentation quality for those in the room, while maintaining visibility for those who are remote.



Whiteboards

Install whiteboards in both individual and shared spaces to support brainstorming and idea-sharing. Enamel-coated steel whiteboards are the most durable. Idea Paint is not recommended except for light use. Glassboards offer a stylish, upscale look but can be harder to read. Consider remote participants when using whiteboards; technologies like "Smartboards" or Miro software can share information effectively with both in-room and remote participants.

## Executive Offices

This large executive office standard features an efficient wrap around workspace while providing room for meetings of four to five people, either at upholstered seats or a table and chairs.

One length of worksurface includes of an adjustable height workstation. Storage consists of a two-drawer lateral file cabinets below the workstation and an optional bookcase.

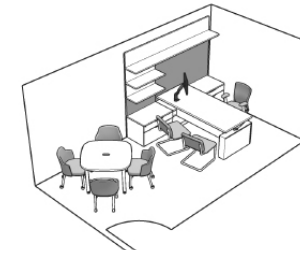

180 s.f.

EXECUTIVE OFFICE

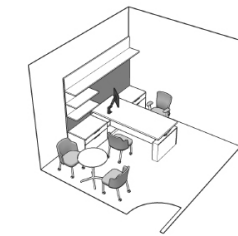

140 s.f.

MANAGER/DIRECTOR OFFICE

Note: Appropriate furniture options will be determined at the time of BBS' assessment of your unique office space.

## SHARED SPACE MODEL POTENTIAL

HOTELING

DESK SHARING

TRADITIONAL SPACE

## Standard Offices

This standard office has an efficient workspace while providing room for meetings of two to three people. One length of worksurface consists of an adjustable height workstation.

Lockable storage for personal belongings should be part of suites that include shared offices or workstations

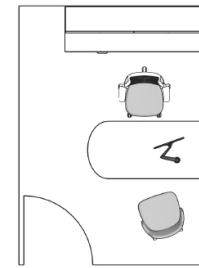
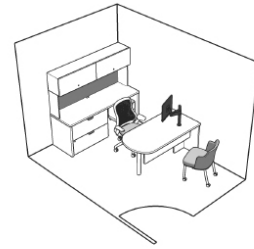

90 s.f.  
STANDARD PRIVATE OFFICE

### SHARED SPACE MODEL POTENTIAL



HOTELING



DESK SHARING



NEIGHBORHOODS



TRADITIONAL SPACE

## Workstations

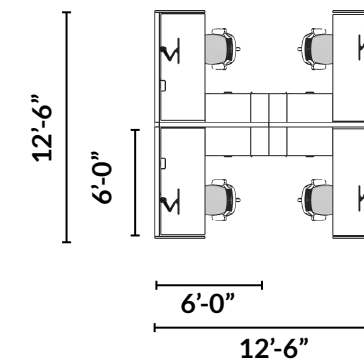
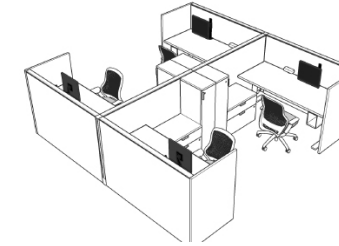

160-200 s.f. total  
36-50 s.f. per workstation  
WORKSTATION CLUSTER

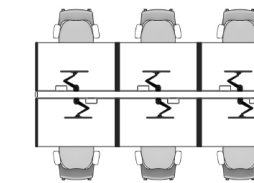

24" x 48"  
HOTELING DESK

Open workstation configuration suitable for telecommuting employees. Dual screens and privacy panels should be designed to work in both seated and standing position. Side privacy is optional.

Permanent storage is not included in unassigned workstations. These small workstations are ideas for hotelling stations or "hot desks" Options are temporary storage include mobile pedestal file cabinets, which can be outfitted with a seat cushion. Group storage lockers provide personal storage for the day.

### SHARED SPACE MODEL POTENTIAL



HOTELING



DESK SHARING



NEIGHBORHOODS



TRADITIONAL SPACE

## Flex Work Space



Tablet tables provide quality working surfaces for these cozier seats.



Flex work spaces can provide employees with cozy, semiprivate environments ideal for internal teamwork and staff collaboration. They are also perfect for interactions with students, visitors and partners. This serves as excellent spaces for individual focus work.

For optimal space utilization, create one, large flex work area on each floor to be shared by all. This will save office space as well as help strengthen the CSULB community.

### SHARED SPACE MODEL POTENTIAL



HOTELING



DESK SHARING



NEIGHBORHOODS



TRADITIONAL SPACE

## Zoom Rooms/Phone Booths



Zoom Rooms provide the solution for CSULB's need for designated zones with controlled sound levels. These rooms will offer private, distraction-free spaces for meetings, featuring optimal lighting and internet connectivity.

With online booking technology, employees can easily schedule these rooms as needed.



### SHARED SPACE MODEL POTENTIAL



HOTELING



DESK SHARING



NEIGHBORHOODS



TRADITIONAL SPACE

## Kitchenettes



Kitchenettes or break rooms are an amenity that is universally cherished by office occupants. The best situations will provide sinks, water coolers, refrigerators and tables. If space does not allow these, a countertop and cabinets with sufficient electrical circuits to power common appliances is a minimum.

Break rooms within an office suite encourage socialization with co-workers. Break rooms outside the office suite can provide an even more informal place to relax away from the workspace and socialize with those from other departments.

### SHARED SPACE MODEL POTENTIAL

 HOTELING

 DESK SHARING

 NEIGHBORHOODS

 TRADITIONAL SPACE

## HELPFUL RESOURCES

The tools below are intended to supplement your discussions as you move through this guide.

### Tool

### Related Page

[CSULB Considerations for Implementing Flexible Work for Staff](#)

*What scheduling options fit your operations, pg. 15*

[Office Operations and Services Modality Matrix](#)

*What scheduling options fit your operations, pg.15*

[Shared Space Strategy Checklist](#)

*Consider these space model best practices, pg. 16*

[Workspace Concept Guides](#)

*Decide the mix of space configurations, pgs. 22-29*

## Contact Us

For support with **Step 1** and **Step 2** of the guide



Future of Work Team  
[Futureofwork@csulb.edu](mailto:Futureofwork@csulb.edu)

For support with **Step 3** of the guide



Beach Building Services (BBS)  
Help Desk  
[BeachBuildingServices@csulb.edu](mailto:BeachBuildingServices@csulb.edu)



Colleen Ryan  
SR. AA Facilities Specialist  
[Colleen.ryan@csulb.edu](mailto:Colleen.ryan@csulb.edu)



# TIPS FOR OFFICE CULTURE & BEAUTIFICATION

## Standard Office Setup

### Equipment, Technology , Security & Sanitation

Creating a consistent and productive work environment regardless of location requires consideration for technology equipment, furniture, and supplies.

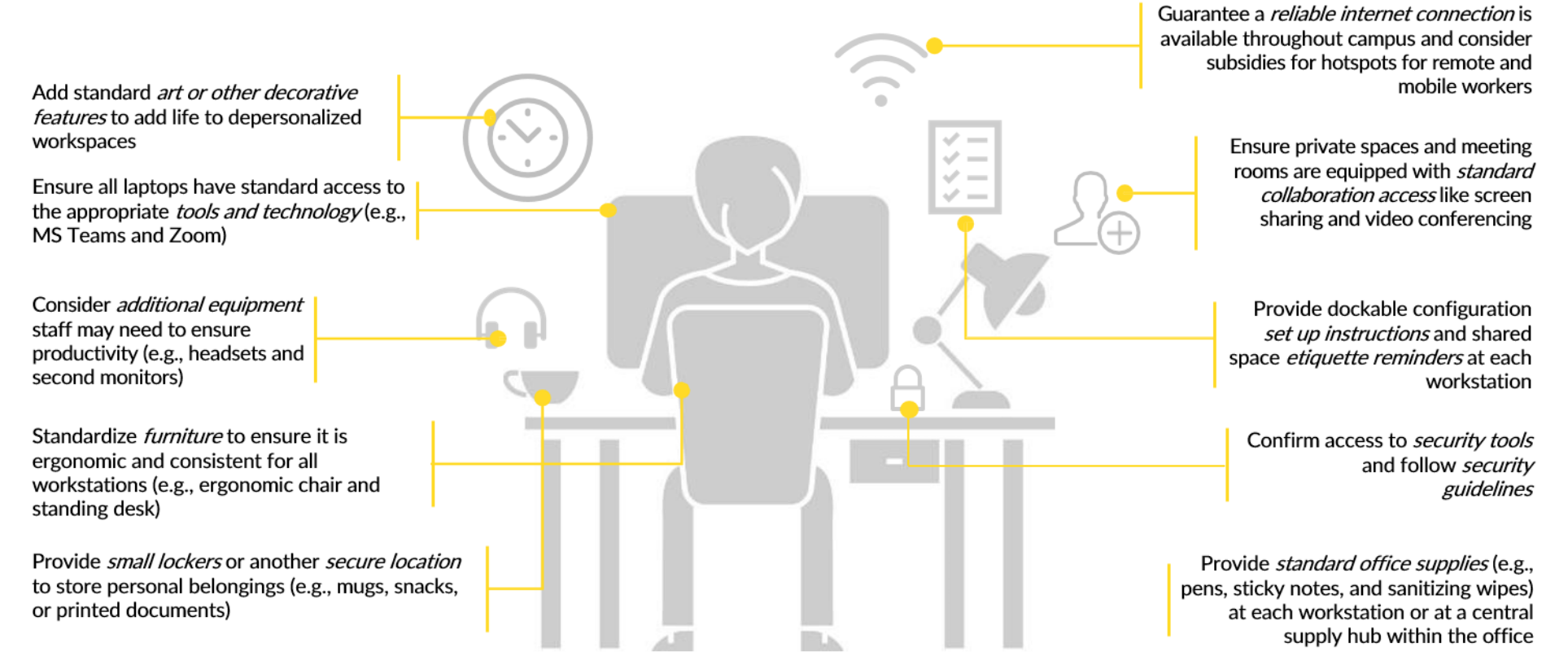

# Designing your Physical Space

The design of your physical office space—the colors, furniture, and equipment you choose—has the potential to inspire and enhance team culture. Architects have long understood this connection between our physical space and our work and mood.

CSULB's BBS team can help you implement these concepts in your office spaces while maintaining consistency with The Beach's [established interior finish palettes](#). These features help achieve a design aesthetic that is both attractive and cohesive across campus.

The next few pages cover some principles of design to consider when configuring your office.



## Strive to Inspire

The office space should spark imagination, creativity, and productivity all while providing comfort and flexibility.

Consider the following factors when setting up your workspace to inspire a shared office culture.

### Natural Light & Elements of Nature

- Have windows to allow natural light to come in
- Have plants, real or fake, around the office

*Connecting to nature can have an impact on mood, well being, and productivity.*

### Create a Serene & Productive Workspace

- Office should be organized and clean
- Be mindful of the colors you use; easy on the eye, but with pops of color

*Reducing the amount of clutter can help to alleviate some visual stress for employees.*

### Foster Social Connection

- Create an open door policy with employees, and provide support
- Encourage team collaboration, support team bonding outings and activities
- Provide a casual open space with soft seating, such as a small lounge or kitchenette with counter-height chairs with power outlets for casual work.

*Having team camaraderie helps lower stress and boosts morale.*



# Psychology of Color

Taking the time to find the right color can improve mood, morale and productivity levels.

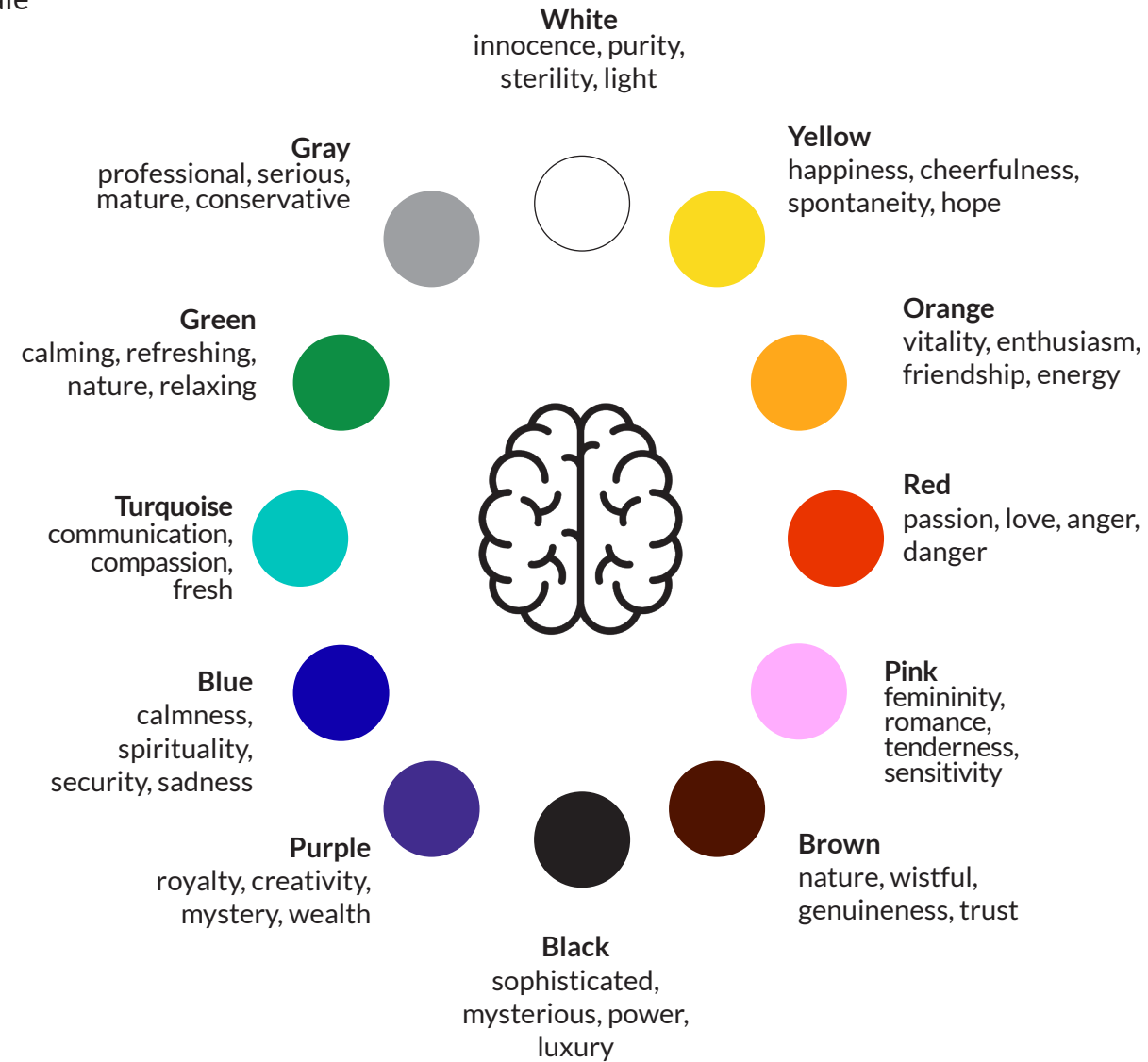

**Use natural materials to warm your space, for example:**

- Wood
- Stone
- Brick
- Glass



**Task and mood lighting or lighting in the right temperature is important.**

Reduce the use of overhead fluorescent lighting where possible

# Add Artwork and Decor

## Branding Treatment Options

BBS can help design and implement branded wall treatments that give life to your workspace.

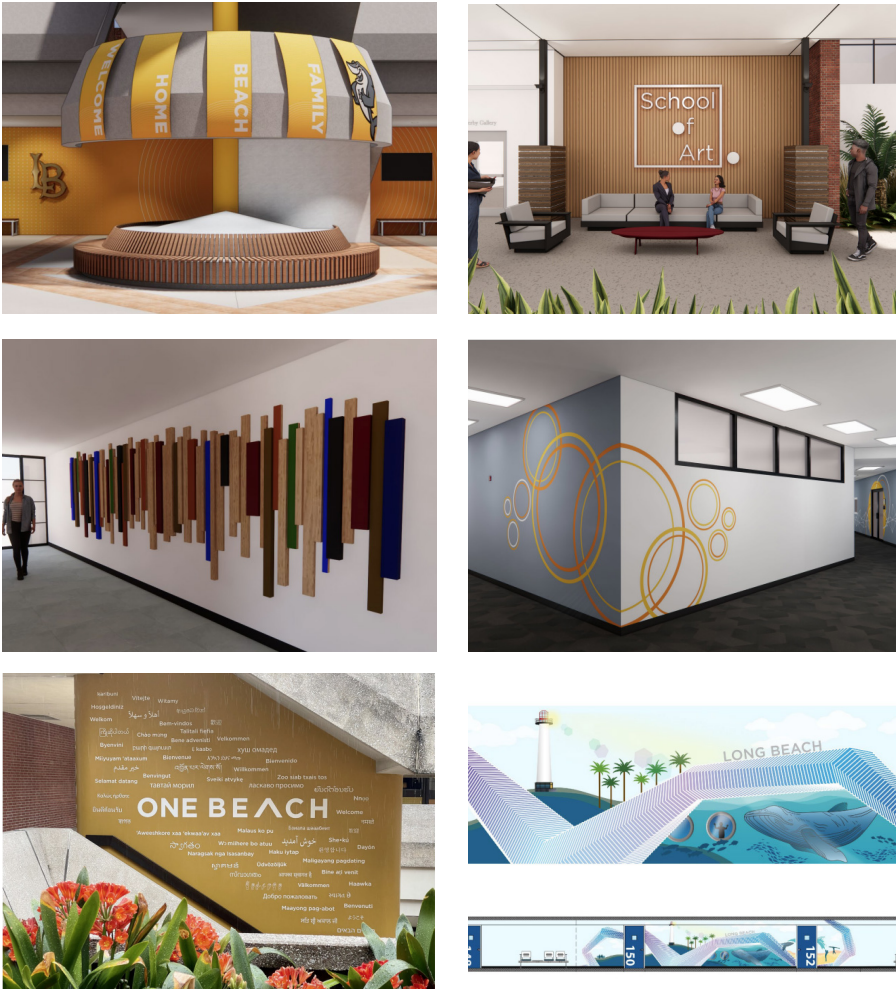

## Printed Artwork Options

Wall art of beautiful campus scenes can be created by the Campus Print Shop from high resolution, copyright-free images, produced by campus Strategic Communications.

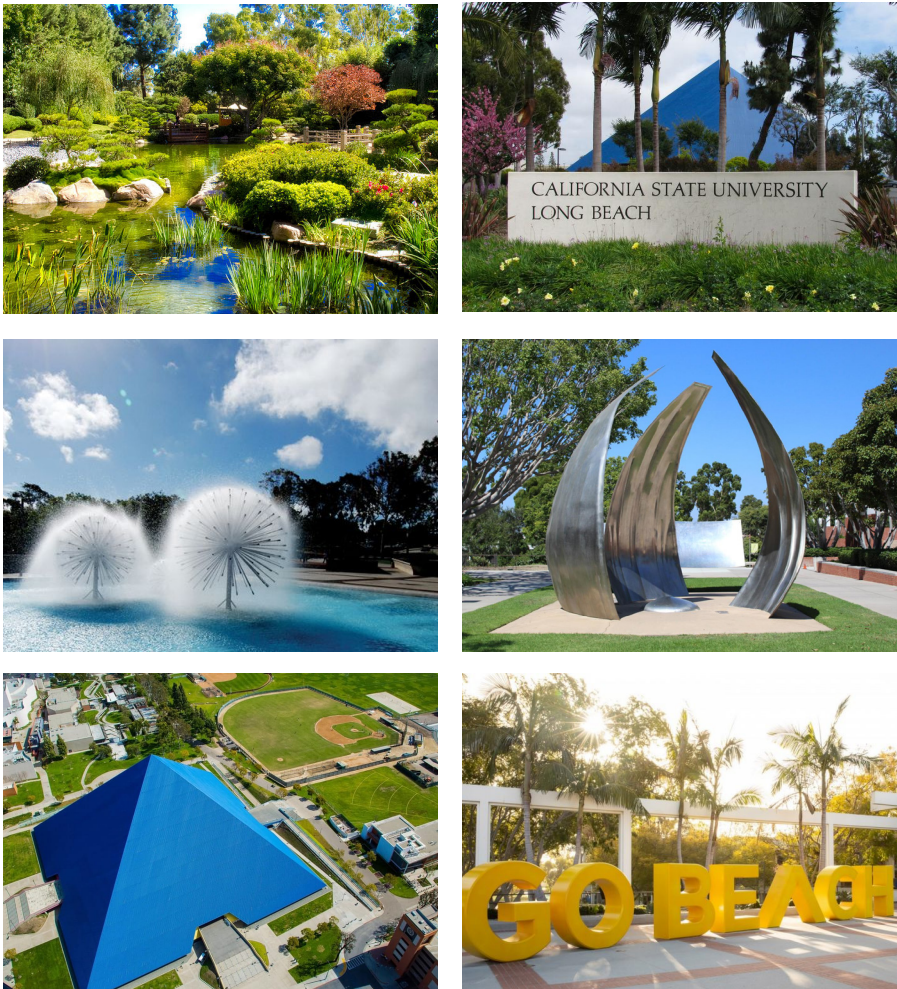

## Showcasing Office Personality

Consider including bulletin boards, pet boards, photos of team activities, department awards displays, wall decals, and common gathering spaces to foster connections within your office and create engaging workspace.





# Utilize Technology

With employees across campus on alternating remote and in-person schedules, there is a need to leverage new technologies that enable streamlined scheduling and office occupancy notifications. Digital signage and event management systems (EMS) are examples.

## Digital Signage

The campus is piloting the use of digital signage in classrooms. CSULB is exploring how we can better use this technology for name plates, conference room, offices and classroom signage to improve identification and use of space.



## Reservation System

The campus is also piloting an Event Management System (EMS) to help notify others of who is working in the office, and provide easy booking on any device. The system has intelligent search, which shows different desk types and different locations / neighborhoods.



**Example:**

New Booking for Tue Jun 11, 2024

<b>Date &amp; Time</b>	<b>Selected Rooms</b>
Date Tue 06/11/2024	Your selected Rooms will appear here.
Start Time 8:00 AM	Room Search Results
End Time 5:00 PM	LIST SCHEDULE
Create booking in this time zone Pacific Time	<input type="checkbox"/> Favorite Rooms only.
	12 AM 1 2 3 4 5 6 7 AM 8 9

# HELPFUL RESOURCES

The tools below are intended to supplement your discussions as you move through this guide.

Tool	Related Page
<a href="#">Brand Central</a>	Add artwork and decor, pg. 46
<a href="#">University Print Shop</a>	Add artwork and decor, pg. 46

## Contact Us

**For support with Office Design and Setup**

**Beach Building Services (BBS)**  
Help Desk  
[BeachBuildingServices@csulb.edu](mailto:BeachBuildingServices@csulb.edu)

**Colleen Ryan**  
SR. AA Facilities Specialist  
[Colleen.ryan@csulb.edu](mailto:Colleen.ryan@csulb.edu)

## Appendix

Tool	Related Page
<a href="#">CSULB Considerations for Implementing Flexible Work for Staff</a>	<i>What scheduling options fit your operations, pg. 15</i>
<a href="#">Office Operations and Services Modality Matrix</a>	<i>What scheduling options fit your operations, pg.15</i>
<a href="#">Shared Space Strategy Checklist</a>	<i>Consider these space model best practices, pg. 16</i>
<a href="#">Workspace Concept Guides</a>	<i>Decide the mix of space configurations, pgs. 22-29</i>
<a href="#">Brand Central</a>	<i>Add artwork and decor</i>
<a href="#">University Print Shop</a>	<i>Add artwork and decor</i>

# Contact Us

Ready to launch a new project? Have a question about this guide?

Our teams are here to support you as you implement these standards in your area.

Reach out! We are ready to hear from you.



**Michael Gardner**  
Director of Campus Planning  
[Michael.Gardner@csulb.edu](mailto:Michael.Gardner@csulb.edu)  
562-985-0123

